



Propane Tank Installation

Propane tank installation is regulated in the state of North Carolina by the Department of Agriculture (www.ncagr.com/standard/sections/lpgasconcerns). CAMA permitting, floodplain development and land disturbance permits are administered by the Town of Duck.

North Carolina State Law: NFPA 58, the LP-Gas Code, "6.6.1.6 Where necessary to prevent flotation due to possible high flood waters around aboveground or mounded containers, or high water table for those underground and partially underground, containers shall be securely anchored. "

FEMA recommended above-ground anchoring technique:

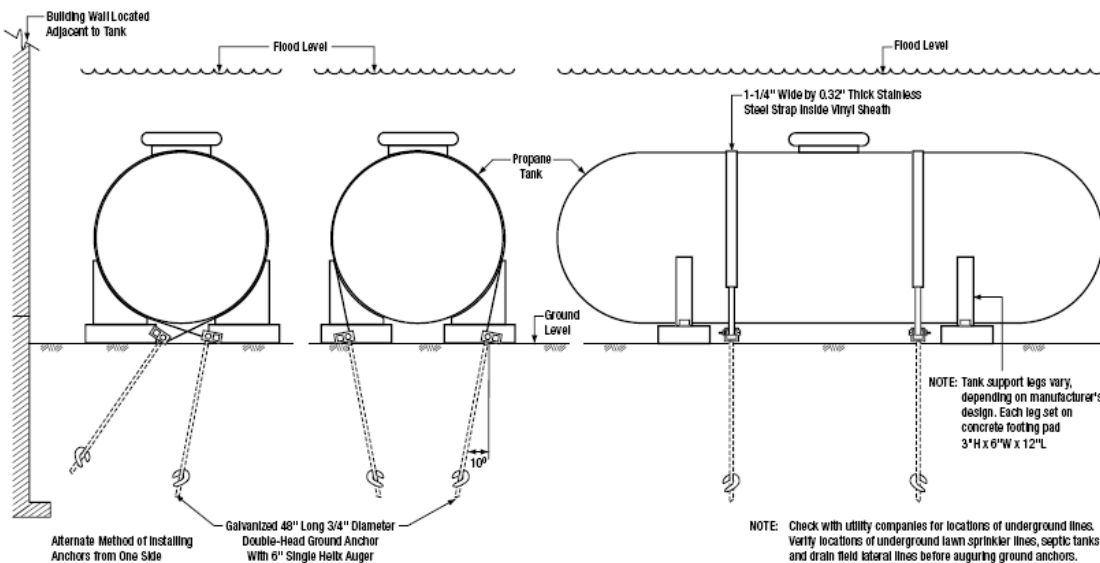

Methods for anchoring propane tanks below ground:

Using the same type mobile home anchors is one accepted way. They need to use an anchor that has some published data about its resistance to pull-out (in pounds) in the type of soil where it is being used. You have to have enough holding force to counteract the buoyancy of an empty tank. Another way that more and more people are using is to put a concrete slab in the hole under the tank and strap the tank to it. Again, the slab has to be heavy enough to keep an empty tank in place. You can't take much credit for the weight of soil on top. It may disappear.

Permitting requirements:

For all underground installations: Land Disturbance Permit

For all above or below-ground installations in a floodplain: Floodplain Development Permit

For all installations in a CAMA Area of Environmental Concern: CAMA permit (may be part of the permit for a new house, if specified, and must be landward of the minimum house setback line)